



S O V E R E L

P E R F O R M A N C E Y A C H T S

320 River Street

PO Box 308

Grand River, Ohio 44045-0308

216/354-5671

S-27
MARK SOVEREL YACHT DESIGNS

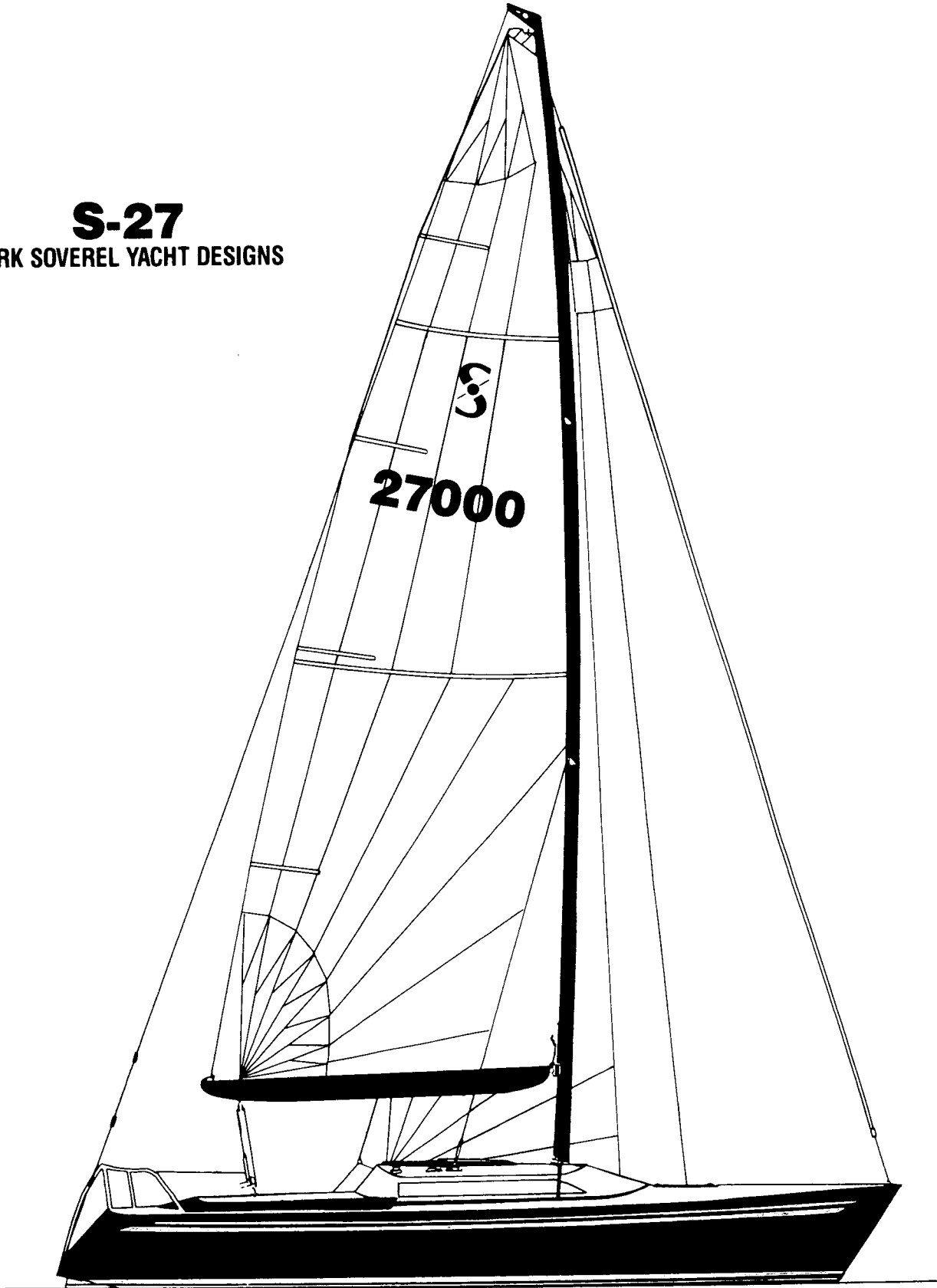

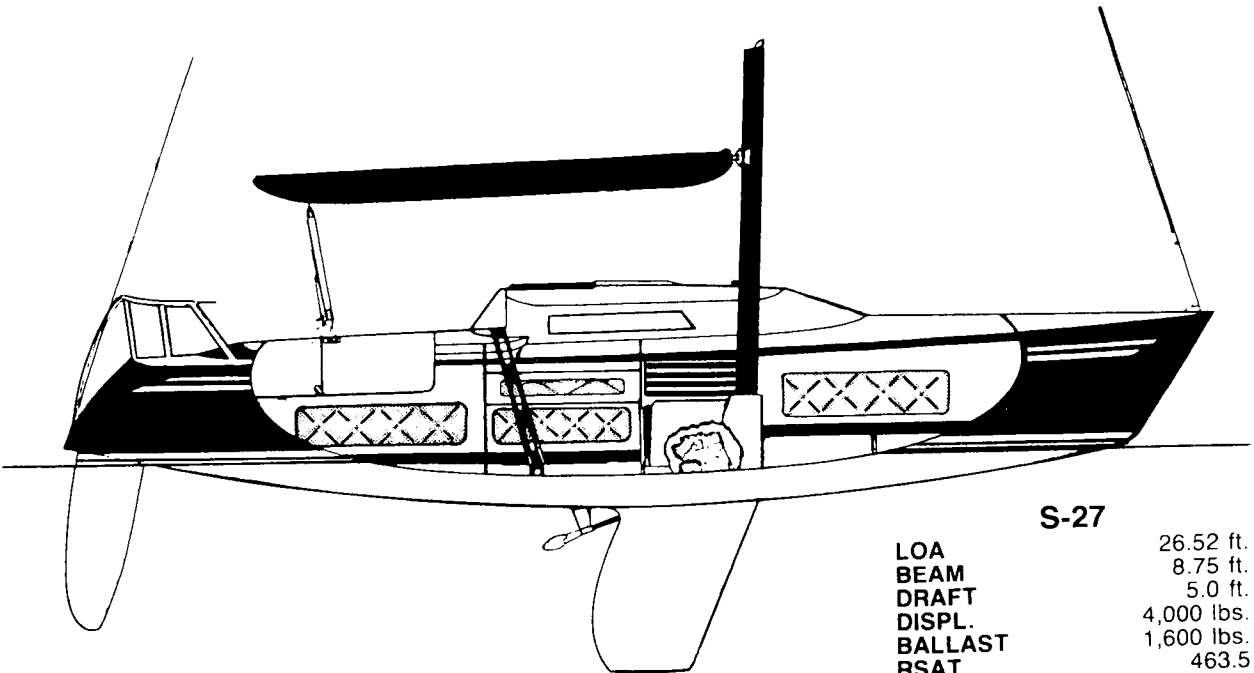
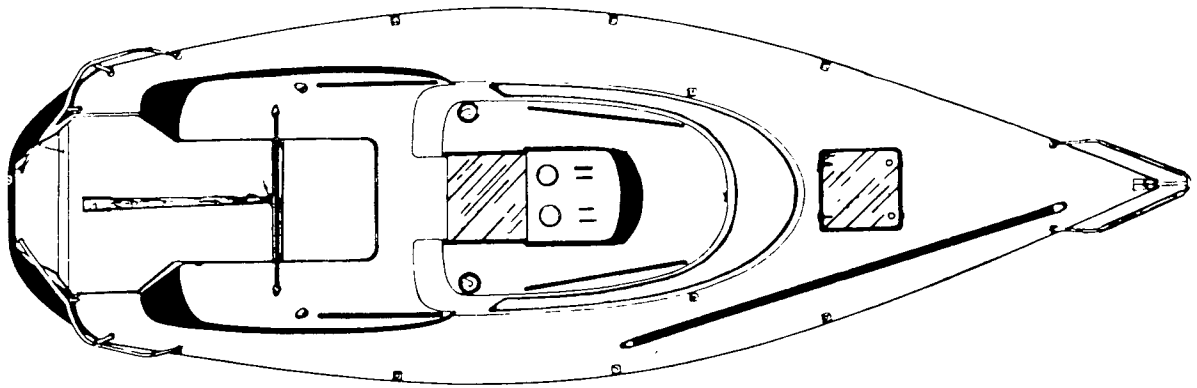

S-27

LOA	26.52 ft.
BEAM	8.75 ft.
DRAFT	5.0 ft.
DISPL.	4,000 lbs.
BALLAST	1,600 lbs.
RSAT	463.5
SA (100%)	362
I	35.0 ft.
J	10.0 ft.
P	33.30 ft.
E	11.28 ft.
MORC RATING (EST)	23.9

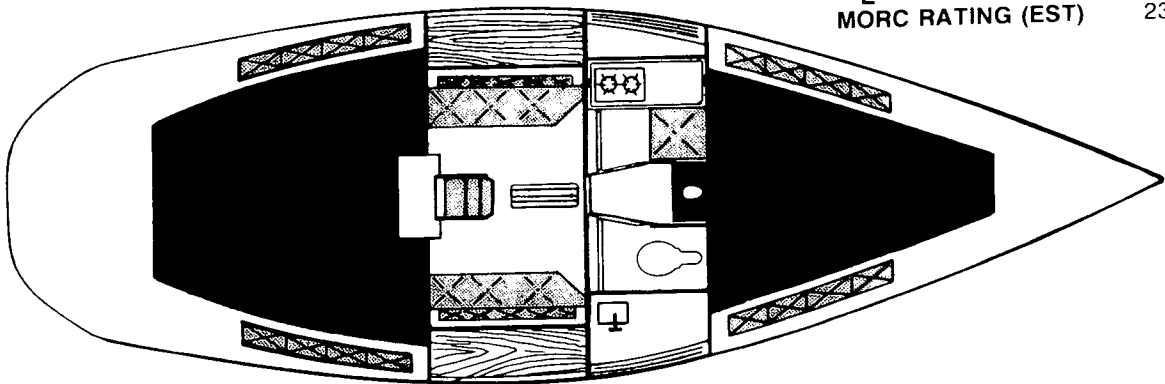

SOVEREL PERFORMANCE YACHTS, INC.
 320 River Street, Grand River, OH 44045 (216) 354-5671

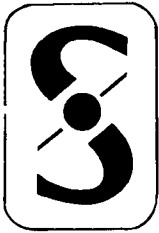

S O V E R E E L

P E R F O R M A N C E Y A C H T S

320 River Street

PO Box 308

Grand River, Ohio 44045-0308

216/354-5671

THE 1987 SOVEREL 27 GENERAL SPECIFICATIONS AND LIST OF STANDARD EQUIPMENT

HULL:

White NPG/150 gelcoat hull consisting of a vinylester resin and 3/4 oz. mat skin coat backed with a 7/16" balsa core covered on both sides with layers of uni-directional "E" glass laid up with polyester resin. Cove stripe and 2" boot stripe standard.

DECK:

White/Sand or Grey

Gelcoated non-skid deck (two tone option) with balsa core laid up in the same manner as the hull.

INTERIOR:

The interior is a modular unit of fiberglass construction trimmed with teak, to provide a warm, comfortable appearance. The three inch firm cushions and backrests are upholstered in a durable fabric (dark blue, burgundy, green, or tan) that attractively sets off the wood trim.

BALLAST:

1,600 pound keel 97% lead/3% antimony of optimum shape is bolted to the hull with stainless steel bolts.

RUDDER:

Hi-tech elliptical rudder is foam cored with a 2" stainless steel shaft.

SPARS/RIGGING:

MAST:

- Polyurethane finished double spreader tapered spar.
- Stainless steel rod rigging.
- 2 — 1 x 19 wire running backstays with Harken blocks and rope tails.
- Harken 20:1 backstay tensioner.
- Spinnaker track, car.
- Spinnaker pole mounted on deck with chocks.

BOOM:

- Polyurethane finished boom.
- 4:1 internal outhaul system.
- Double reef lines.
- 8:1 Harken mechanical boom vang.

(continued)

General Specifications (continued)

DECK HARDWARE:

- Stainless steel bow and stern pulpits with stern gate.
- 18" single lifelines.
- Custom stainless steel stemhead with tack horns.
- 1 inch wide Merriman inboard genoa track.
- 2 — wide sheave genoa cars.
- 2 — sliding toe rail cars.
- Merriman "T" toe rail track 1 inch outboard at deck edge.
- 2 — Barient #22A primary winches.
- 2 — Barient #18A secondary/halyard winches.
- 2 — Barient winch handles.
- 4 — rope clutches.
- 6 — Harken Cammatic cam cleats.
- Harken ball bearing traveler control system.
- Harken main 4:1 sheet system with 16:1 fine tune adjustment.
- 2 — spinnaker sheet turning blocks.
- 1 — foreguy swivel block and fairlead.

ELECTRICAL SYSTEM:

- 12 volt battery with switch panel.
- Cabin lights.
- Running lights.

GALLEY/INTERIOR:

- Stainless steel sink with salt water system.
- Stove area.
- 9 — storage lockers.

RUNNING RIGGING:

- 1 — low stretch main sail halyard with shackle.
- 2 — wire/rope halyards with shackles (Genoa/Spinnaker).
- 1 — rope topping lift with shackle.
- 2 — Dacron genoa sheets.
- 2 — Dacron spinnaker sheets with shackles.
- 1 — foreguy with shackle.
- 1 — mainsheet.
- 1 — main cunningham.
- 2 — reef lines.
- 2 — spinnaker twing lines.

FOB: factory of origin.

Pricing and specifications are based on current design information and are subject to change at any time including after receipt of order until final delivery. All prices are F.O.B. plant of origin. Manufacturer and model numbers of various components are used to define type, size and quality. Builder reserves the right to substitute equivalent components at any time.

Effective: June 5, 1986.